

MC68EC030

Addendum

MC68EC030 32-Bit Embedded Controller User's Manual

April 17, 1996

This addendum to the initial release of the MC68EC030 User's provides additional information not included in the original (or corrections to the original text). This document and other information on this product is maintained on the AESOP BBS, which can be reached at (800) 843-3451 (from the U.S. and Canada) or (512) 891-3650. Configure modem for up to 14.4 Kbaud, 8 bits, 1 stop bit, and no parity. Terminal software should support VT100 emulation. Internet access is provided by telneting to pirs.aus.sps.mot.com [129.38.233.1] or through the World Wide Web at <http://pirs.aus.sps.mot.com>.

Incorporate the following information into the manual. This addendum contain information on junction temperatures for the pin grid array package and 132-lead ceramic surface mount package. A pinout and the case package is also given for the 132-lead ceramic surface mount and 144-lead TQFP (PV Suffix) package.

This document contains information on a product under development. Motorola reserves the right to change or discontinue this product without notice.

SEMICONDUCTOR PRODUCT INFORMATION

Freescale Semiconductor, Inc.

The following tables define the maximum junction temperature for the PPGA and FE packages for the MC68EC030.

Maximum Junction Temperature for PPGA Package

T_J Max. = 115 °C

Maximum ambient temperature (°C) vs. airflow and rated frequency—PPGA without heatsink.

Frequency MHz	PD Max. at T_J Max. Watts	Air Flow in linear feet/minute				
		0*	100	200	400	500
40	1.55	65	72	75	79	81
33.33	1.40	70	76	79	83	84
25	1.25	75	80	83	86	88
20	1.15	78	83	85	89	90
16.67	1.10	80	84	86	90	91

Typical junction temperature (°C) for operations at T_A Max. above—PPGA without heatsink.

Frequency MHz	PD Typical Watts	Air Flow in linear feet/minute				
		0*	100	200	400	500
40	0.95	96	98	99	101	102
33.33	0.85	97	100	101	102	103
25	0.75	99	101	102	104	104
20	0.65	99	101	102	104	104
16.67	0.60	99	101	102	104	104

Maximum Power Dissipation vs. Frequency—PPGA Package

Frequency MHz	PD Max. at $T_A = 0^\circ$ Watts
40	1.80
33.33	1.60
25	1.40
20	1.30
16.67	1.20

Theta J_A vs. Airflow—PPGA Package without heatsink (estimated)

Air Flow in linear feet/minute				
0*	100	200	400	500
32	28	26	23	22

* Natural Convection

Freescale Semiconductor, Inc.

Maximum Junction Temperature for FE package—without heatsink

T_J Max. = 115 °C

Maximum ambient temperature (°C) vs. airflow and rated frequency—FE without heatsink.

Frequency MHz	PD Max. at T_J Max. Watts	Air Flow in linear feet/minute				
		0*	100	200	400	500
40	1.55	44	61	72	76	78
33.33	1.40	51	66	76	80	81
25	1.25	58	71	80	84	85
20	1.15	62	75	83	86	87
16.67	1.10	64	77	84	88	89

Typical junction temperature (°C) for operations at T_A Max. above—FE without heatsink.

Frequency MHz	PD Typical Watts	Air Flow in linear feet/minute				
		0*	100	200	400	500
40	0.95	87	94	98	100	101
33.33	0.85	90	96	100	101	102
25	0.75	92	98	101	103	103
20	0.65	92	98	101	103	103
16.67	0.60	92	98	101	103	103

Maximum Power Dissipation vs. Frequency—FE Package

Frequency MHz	PD Max. at $T_A = 0^\circ$ Watts
40	1.80
33.33	1.60
25	1.40
20	1.30
16.67	1.20

Theta J_A vs. Airflow—FE Package without heatsink (estimated)

Air Flow in linear feet/minute				
0*	100	200	400	500
46	35	28	25	24

* Natural Convection

Freescale Semiconductor, Inc.

Maximum Junction Temperature for FE package—with heatsink

T_J Max. = 115 °C

Maximum ambient temperature (°C) vs. airflow and rated frequency—FE with heatsink.

Frequency MHz	PD Max. at T_J Max. Watts	Air Flow in linear feet/minute				
		0*	100	200	400	500
40	1.55	61	76	84	86	87
33.33	1.40	66	80	87	88	90
25	1.25	71	84	90	91	93
20	1.15	75	86	92	93	94
16.67	1.10	77	88	93	94	95

Typical junction temperature (°C) for operations at T_A Max. above—FE with heatsink.

Frequency MHz	PD Typical Watts	Air Flow in linear feet/minute				
		0*	100	200	400	500
40	0.95	94	100	103	104	104
33.33	0.85	96	101	104	105	105
25	0.75	98	103	105	106	106
20	0.65	98	103	105	106	106
16.67	0.60	98	103	105	106	106

Maximum Power Dissipation vs. Frequency—FE Package

Frequency MHz	PD Max. at $T_A = 0^\circ$ Watts
40	1.80
33.33	1.60
25	1.40
20	1.30
16.67	1.20

Theta J_A vs. Airflow—FE Package with heatsink (estimated)

Air Flow in linear feet / minute				
0*	100	200	400	500
35	25	20	19	18

* Natural Convection

The following figures provide a pinout and the mechanical dimensions for the 132-Lead Surface Mount (FE Suffix) and 144-Lead Thin Quad Flat Pack TQFP (PV Suffix).

FE SUFFIX PACKAGE
CASE 831-01

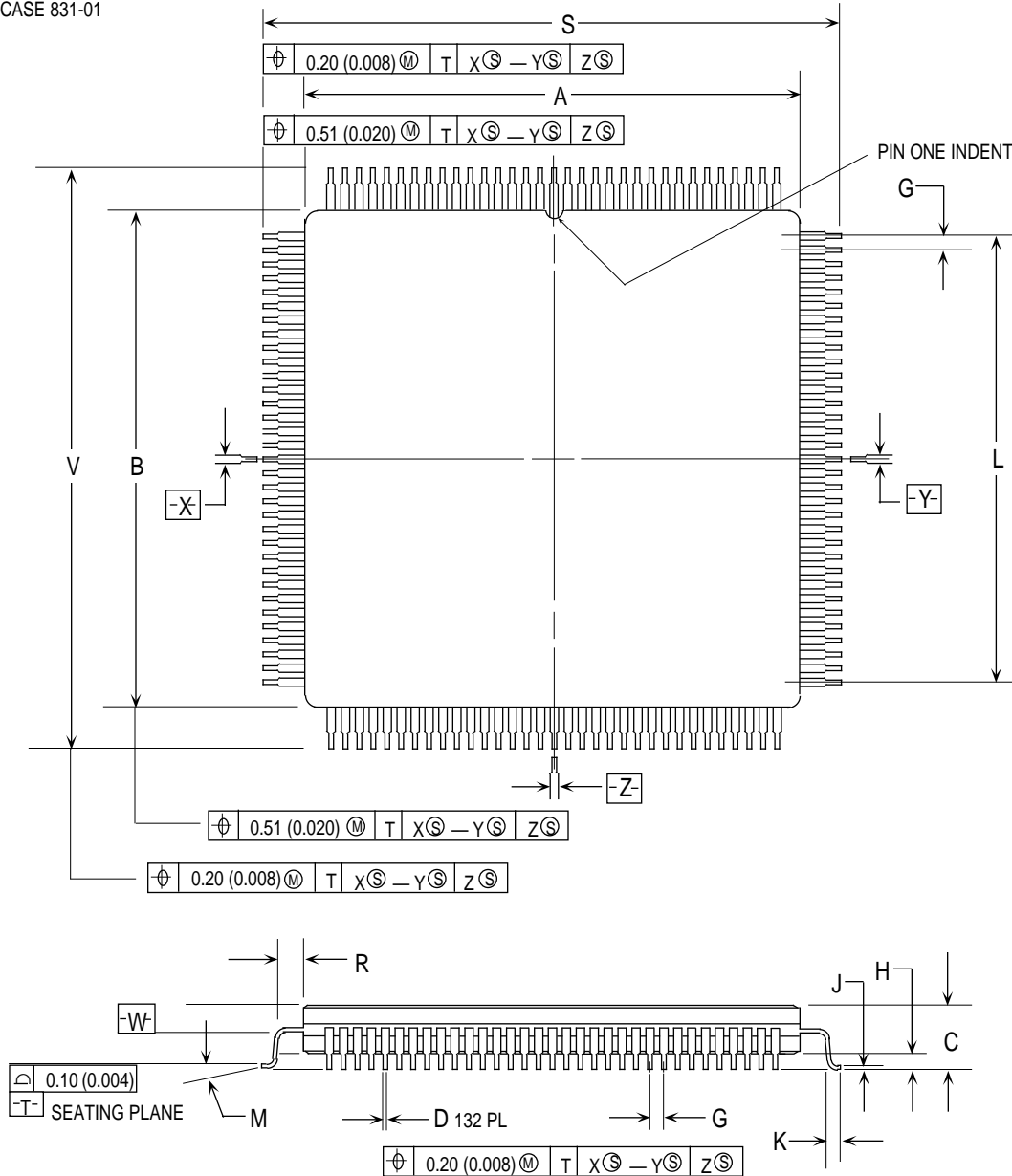

DIM	MILLIMETERS		INCHES	
	MIN	MAX	MIN	MAX
A	21.85	22.86	0.860	0.900
B	21.85	22.86	0.860	0.900
C	3.94	4.31	0.155	0.170
D	0.204	0.292	0.0080	0.0115
G	0.64 BSC		0.025 BSC	
H	0.64	0.88	0.025	0.035
J	0.13	0.20	0.005	0.008
K	0.51	0.76	0.020	0.030
L	20.32 REF		0.800 REF	
M	0°	8°	0°	8°
R	0.64	—	0.025	—
S	27.31	27.55	1.075	1.085
V	27.31	27.55	1.075	1.085

NOTES:

1. DIMENSIONING AND TOLERANCING PER ANSI Y14.5M, 1982.
2. CONTROLLING DIMENSION: INCH
3. DIM A AND B DEFINE MAXIMUM CERAMIC BODY DIMENSIONS INCLUDING GLASS PROTRUSION AND MISMATCH OF CERAMIC BODY TOP AND BOTTOM.
4. DATUM PLANE -W- IS LOCATED AT THE UNDERSIDE OF LEADS WHERE LEADS EXIT PACKAGE BODY.
5. DATUMS X-Y AND Z TO BE DETERMINED WHERE CENTER LEADS EXIT PACKAGE BODY AT DATUM -W-.
6. DIM S AND V TO BE DETERMINED AT SEATING PLANE, DATUM -T-.
7. DIM A AND B TO BE DETERMINED AT DATUM PLANE -W-.

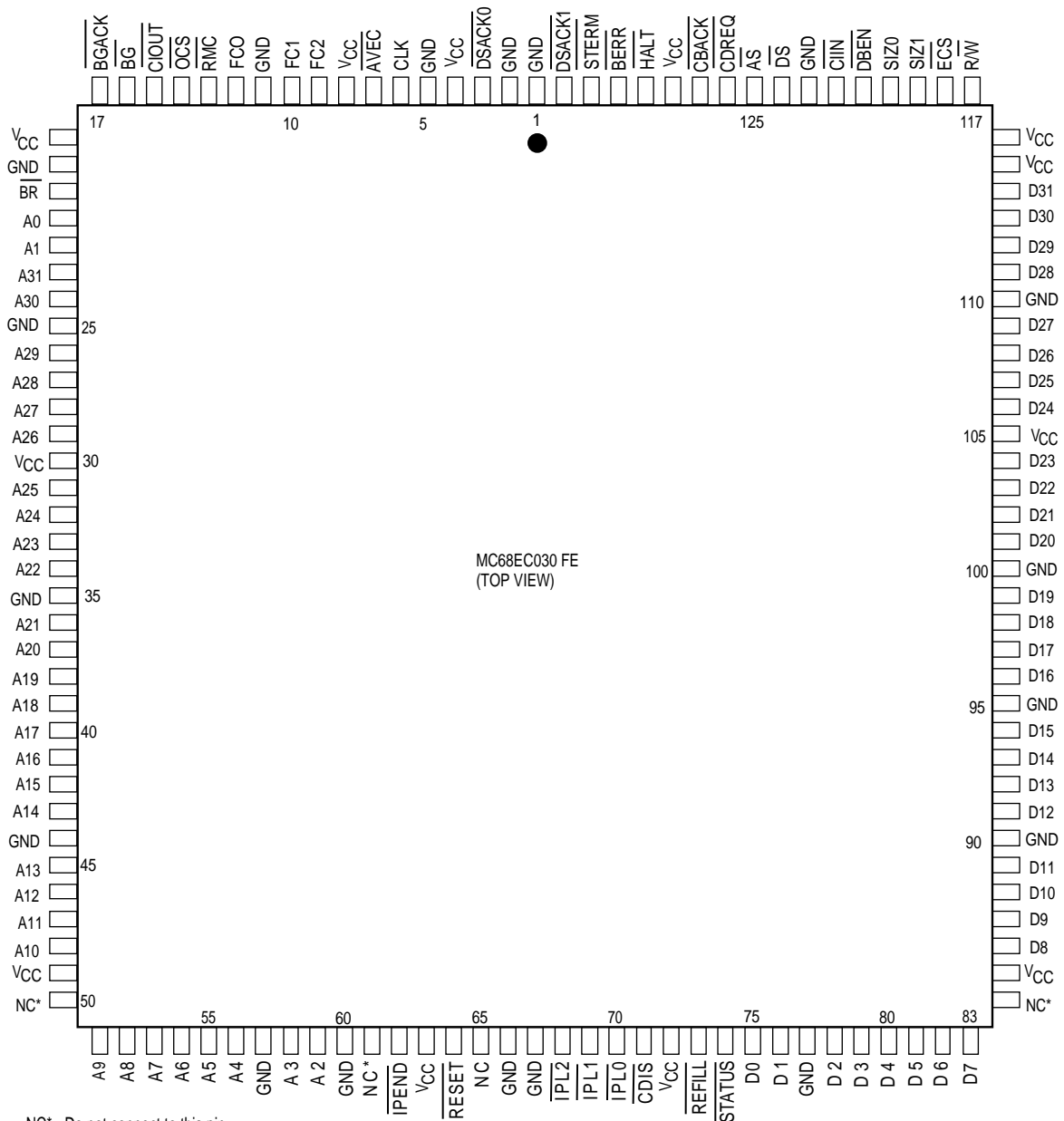

NC* - Do not connect to this pin.

CASE 918-02
144 TQFP

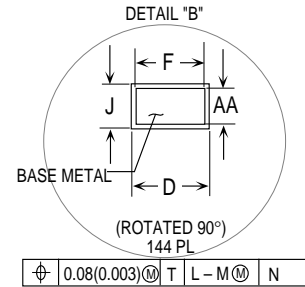
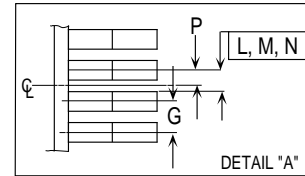
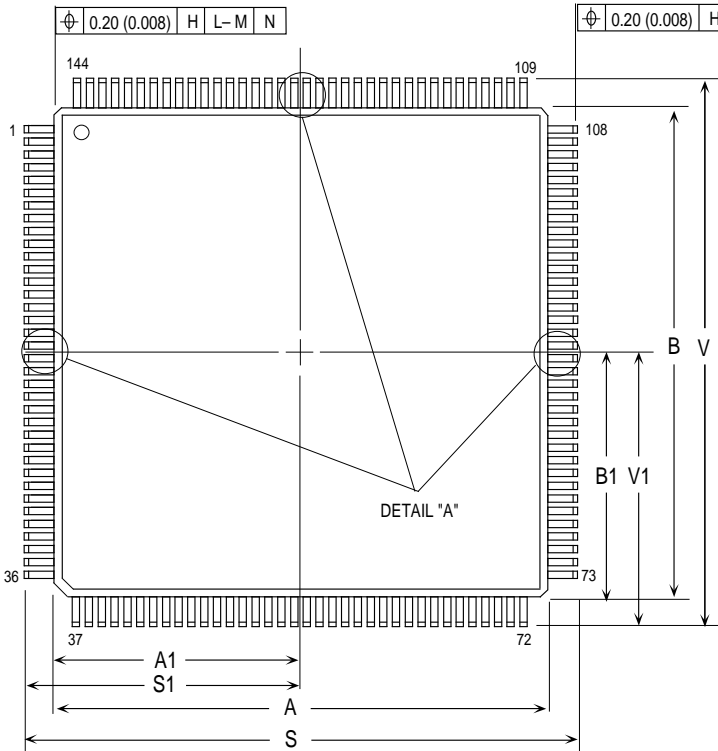

NOTES:

1. DIMENSIONING AND TOLERANCING PER ANSI Y14.5M, 1982.
2. CONTROLLING DIMENSION: MILLIMETER.
3. DATUM PLANE -H- IS LOCATED AT BOTTOM OF LEAD AND COINCIDENT WITH THE LEAD WHERE THE LEAD EXITS THE PLASTIC BODY AT THE BOTTOM OF THE PARTING LINE.
4. DATUMS -L-, -M-, AND -N- TO BE DETERMINED AT DATUM PLANE -H-.
5. DIMENSIONS S AND V TO BE DETERMINED AT SEATING PLANE -T-.
6. DIMENSIONS A AND B DO NOT INCLUDE MOLD PROTRUSION. ALLOWABLE PROTRUSION IS 0.25 (0.010) PER SIDE. DIMENSIONS A AND B DO NOT INCLUDE MOLD MISMATCH AND ARE DETERMINED AT DATUM LINE -H-.
7. DIMENSION D DOES NOT INCLUDE DAMBAR PROTRUSION. ALLOWABLE DAMBAR PROTRUSION SHALL NOT CAUSE THE D DIMENSION TO EXCEED 0.35 (0.014).

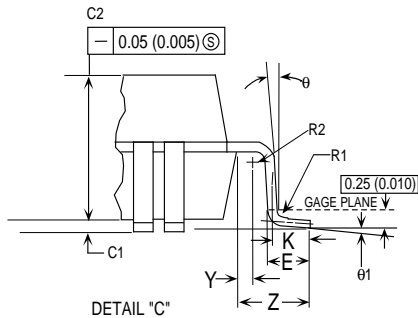
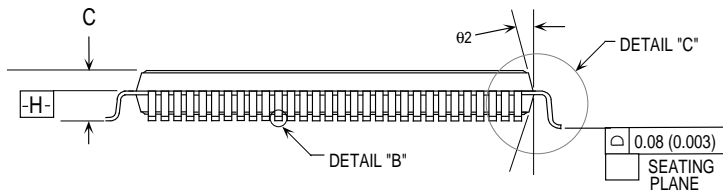

DIM	MILLIMETERS		INCHES	
	MIN	MAX	MIN	MAX
A	20.00 BSC		0.790 BSC	
A1	10.00 BSC		0.394 BSC	
B	20.00 BSC		0.790 BSC	
B1	10.00 BSC		0.394 BSC	
C	1.40	1.60	0.055	0.063
C1	0.05	0.15	0.002	0.006
C2	1.35	1.45	0.053	0.057
D	0.17	0.27	0.007	0.011
E	0.45	0.75	0.018	0.030
F	0.17	0.23	0.007	0.009
G	0.50 BSC.		0.20 BSC.	
J	0.09	0.20	0.004	0.008
K	0.50 REF		0.020 REF	
P	0.25 BSC		0.010 BSC	
R1	0.13	0.20	0.005	0.008
R2	0.13	0.20	0.005	0.008
S	22.00 BSC		0.866 BSC	
S1	11.00 BSC		0.433 BSC	
V	22.00 BSC		0.866 BSC	
V1	11.00 BSC		0.433 BSC	
Y	0.25 REF		0.010 REF	
Z	1.00 REF		0.039 REF	
AA	0.09	0.16	0.004	0.006
θ	0°		0°	
θ_1	0°	7°	0°	7°
θ_2	11°	13°	11°	13°

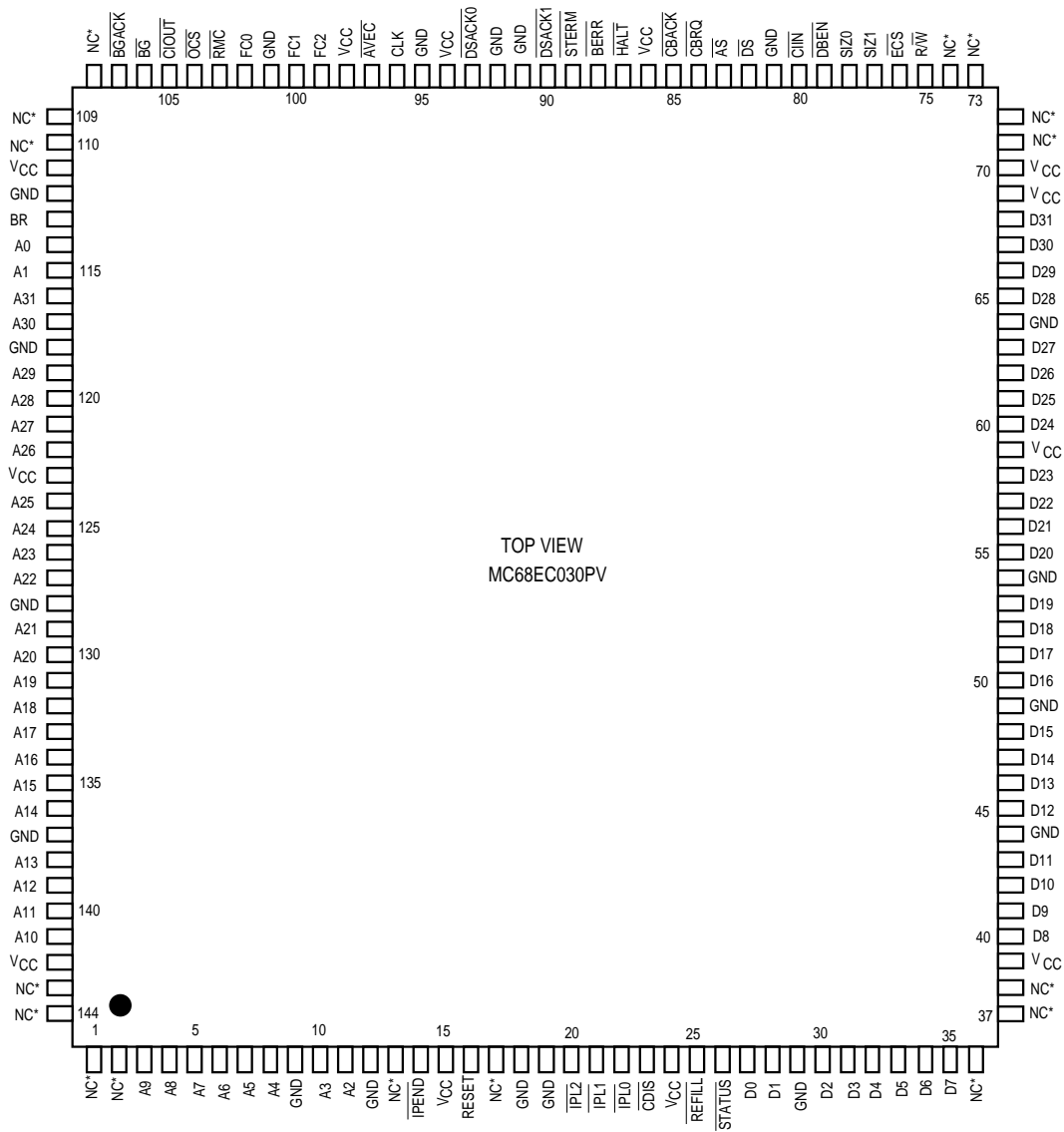

NC*—Do not connect to this pin.

Motorola reserves the right to make changes without further notice to any products herein. Motorola makes no warranty, representation or guarantee regarding the suitability of its products for any particular purpose, nor does Motorola assume any liability arising out of the application or use of any product or circuit, and specifically disclaims any and all liability, including without limitation consequential or incidental damages. "Typical" parameters can and do vary in different applications. All operating parameters, including "Typicals" must be validated for each customer application by customer's technical experts. Motorola does not convey any license under its patent rights nor the rights of others. Motorola products are not designed, intended, or authorized for use as components in systems intended for surgical implant into the body, or other applications intended to support or sustain life, or for any other application in which the failure of the Motorola product could create a situation where personal injury or death may occur. Should Buyer purchase or use Motorola products for any such unintended or unauthorized application, Buyer shall indemnify and hold Motorola and its officers, employees, subsidiaries, affiliates, and distributors harmless against all claims, costs, damages, and expenses, and reasonable attorney fees arising out of, directly or indirectly, any claim of personal injury or death associated with such unintended or unauthorized use, even if such claim alleges that Motorola was negligent regarding the design or manufacture of the part. Motorola and are registered trademarks of Motorola, Inc. Motorola, Inc. is an Equal Opportunity/Affirmative Action Employer.

Literature Distribution Centers:

USA/EUROPE: Motorola Literature Distribution; P.O. Box 20912, Arizona 85036. 1-800-441-2447

JAPAN: Nippon Motorola Ltd.; 4-32-1, Nishi-Gotanda, Shinagawa-ku, Tokyo 141 Japan.

HONG KONG: Motorola Semiconductors H.K. Ltd.; Silicon Harbour Center, No. 2 Dai King Street, Tai Po Industrial Estate,